

Converting a 27 inch 2011 iMac to a Standalone 2K Display

The details below are based on my own conversion experience and choices I made. It would not have been successful without the numerous posts across various MacRumors Forum threads and other websites – others that have attempted this conversion before me and contributed to the forums and websites deserve a great deal of credit.

The processes below document how I was able to use both **the original iMac power supply and the original iMac inverter board** for my conversion. **This completely eliminated the brightness issues** of the constant current boards that are commonly supplied with the LCD driver boards for these screens. The key was to learn how the iMac power supply and the inverter board work. Essentially, we are trying to replicate how the power supply, inverter board, and the main logic board function in the iMac and then figuring out how to preserve the functionality of the power supply and inverter board *without* the main logic board present.

There are graphics on the last page of this document that show the connections between the components. I think they will be helpful as you work through the details of this guide.

Note: Using some of the components below will require soldering in some cases, but it is not complex.

- *My soldering skills are not good*, but they were adequate for the amount of soldering for this conversion
- It may be possible to do this conversion without soldering, but you will need to find some different components than some of those that I used (e.g., using wire nuts or screw type wire connectors on PCBs)

Original iMac Specs

- 2011 27-inch iMac with i5 2400 and i7-2600 CPU
- None GB RAM
- AMD WX7100 graphics card with 8GB
- 1 TB SSD, 750 GB and 320 GB HDD
- Using OpenCore to support running MacOS versions beyond High Sierra

My Plan – Convert the iMac to a standalone display while also keeping the following pre-conversion internal components in place:

- Power supply
- Inverter board
- Speakers
- 2x 2.5" HDDs (I am using the SSD for other purposes)
- SuperDrive
- **SD card reader (I probably won't go to the effort to connect this – I don't use it often and have other SD card readers to use if I need one)**

Required Parts (Links below are the components I used, but others may also be suitable)

- LCD driver board – the main sources for these are eBay and AliExpress and are specific to your display model (this will likely come with a constant current board which will no longer be used after this conversion)
- [Latching pushbutton](#) (to turn the display and power supply on/off – I did not connect the LED leads)
- [Momentary pushbuttons](#) (to control brightness via the PWM board instead of using software)
- [Step down voltage converter](#) (to supply 3.3 Vdc to the PWM signal generator board)
- [PWM signal generator](#) (supplies the PWM signal to the iMac inverter board)
- [SparkFun Buck Regulator](#) (to supply 3.3 Vdc to the iMac inverter board - **maintains display sleep functionality**)
- [Crossover boards](#) for speaker functionality (these are large in size probably overkill given their 400W rating, but they were not expensive and the wiring connectors are easy – if I had to do this again I would probably use something smaller in size)
- [Small fan](#) for cooling and a [temperature controlled fan PWM](#) (This PWM can control 2 fans independently)

- A suitable USB 3.X hub (I already had [one of these](#) that I didn't use very often)
- [SATA to USB 3.0 hard drive adapters](#) (make sure the USB connector style is same as the hub)
- [Slimline SATA to USB 3.0 adapter](#) for the SuperDrive (make sure the USB connector style is same as the hub)
- [Power connectors](#) to connect the power supply to the LCD driver board (ensure you get the right internal size for your board – 2.1 mm or 2.5 mm)
- [Plastic standoff mounts](#) with adhesive
- [Double sided gorilla tape](#) to improve the adhesion of the standoff mounts when mounting some items to the iMac chassis
- Scrap plastic pieces for board backing
- Electrical tape / Kapton tape

Mounting Considerations

- Layout your components ahead of time to simulate how and where you will mount each item in the iMac case
- Care must be taken to prevent your components from contacting metal parts of the iMac case and causing a short. Several solutions to this:
 - Some people have used 3D printers to design mounting boards for their components. This provides for a very clean and neat installation if you have access to a 3D printer.
 - Use the plastic standoff mounts. Be certain the adhesive is strong enough to hold the component in place
 - I used scrap plastic pieces cut to size for *some* of the boards in combination with the standoff mounts and the double-sided mounting tape to effectively and securely mount the components. Tape the cut plastic pieces to the iMac case, apply another piece of double-sided tape to the exposed plastic area, and then attach the board with the standoff mounts to the plastic/tape. (This is the method I used for some of the circuit boards on my conversion.)

Figuring Out the Power Supply and Control Signal paths

Understanding the iMac power supply unit (PSU) – 16 pin MOLEX connector

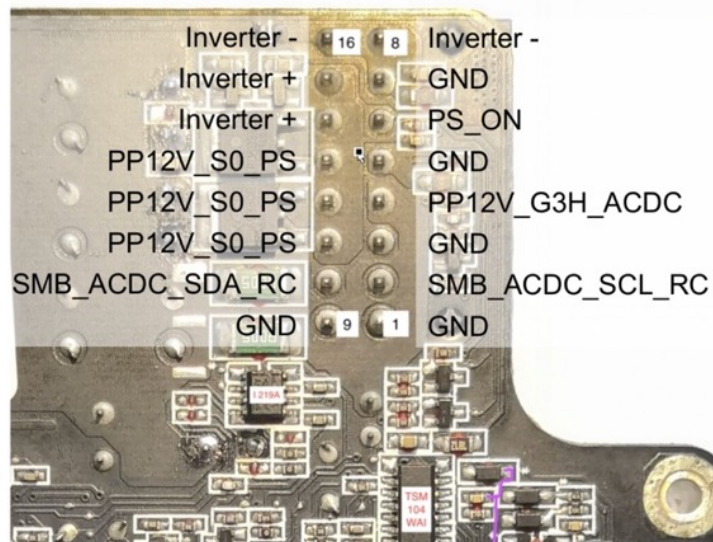

1. The iMac power supply uses a 16-pin MOLEX connector to connect it to the inverter board and the main logic board. **ENSURE YOU KEEP THIS CONNECTOR AND THE WIRES GOING INTO IT INTACT!!**
2. Until it is commanded to turn on, all the pins *except Pin 4 and Pin 6* of the power supply remain de-energized when plugged into the wall outlet. Pin 4 (PP12V_G3H_ACDC) always has 12Vdc available anytime the unit is plugged in (see Pin 4 details below).

3. To command the power supply to turn on, Pin 6 (PS_ON) must be triggered by shorting it to ground.
- *The existing iMac power button will not work for this since it is a momentary pushbutton instead of a latching pushbutton* (the iMac main logic board keeps the PS_ON triggered via electronic means that are not available on the LCD driver board).
 - For my conversion, I connected Pin 6 to Pin 7 (GND) with a [latching pushbutton](#) connected to their wires coming from the 16-pin MOLEX connector. This provides a way to directly energize the power supply, the display, and the internal components and does not require connecting the existing iMac power button to the LCD driver board control strip.

4. The table below shows the expected readings from the power supply for when the PS_ON pin is triggered and not triggered.
- When the power supply gets triggered by shorting pin 6 to GND, you get three additional 12Vdc power lines from pins 11, 12, and 13 to use for the internal components and two 12Vdc power lines to supply the inverter.
 - I used the two of the three lines from pins 11, 12, and 13 exclusively for power to the LCD driver board and the fan controller board.
 - *I did **not** use pin 4 for anything since I did not want any of the internal components to be powered all the time just because the cord is plugged into the wall outlet.*

PS_ON triggered / not triggered (all values are Vdc)

Pin 1 (GND)	0 / 0	Pin 9 (GND)	0 / 0
Pin 2 (SMB_ACDC_SCL_RC)	~2.9 / ?	Pin 10 (SMB_ACDC_SDA_RC)	~2.6 / ?
Pin 3 (GND)	0 / 0	Pin 11 (PP12V_S0_PS)	12 / 0
Pin 4 (PP12V_G3H_ACDC)	12 / 12	Pin 12 (PP12V_S0_PS)	12 / 0
Pin 5 (GND)	0 / 0	Pin 13 (PP12V_S0_PS)	12 / 0
Pin 6 (PS_ON)	0 / ~4	Pin 14 (Inverter +)	12 / 0
Pin 7 (GND)	0 / 0	Pin 15 (Inverter +)	12 / 0
Pin 8 (Inverter -)	0 / 0	Pin 16 (Inverter -)	0 / 0

? = I did not measure these two when PS_ON was not triggered

Power supply pin functional descriptions

GND = Ground (pins 1,3,5,7,9)

PP12V_G3H_ACDC = Always on Standby Power for some of the system management controller functions (pin 4).
For example (not an all inclusive list):

- Standby mode function of the Bluetooth controller to support waking the system up from sleep using the Bluetooth keyboard or mouse
- Wake On LAN functionality of the ethernet port
- *12Vdc from this connection is present anytime the computer is plugged in to the wall outlet*

PS_ON = Power Supply On (pin 6).

- The power supply remains off unless it gets triggered to turn on.
- Normally, the PS_ON port would get triggered by the iMac motherboard to energize the power supply when the power button is pressed.
 - In order to use the inverter, a new method to trigger the power supply to come on is required.
 - I used a latching push button like this – [pushbutton](#) – to connect PS_ON (Pin 6) to GND (Pin 7).
 - The PS_ON port must remain triggered for the power supply to maintain its energized state, therefore it requires a latching push button, not a momentary push button

PP12V_S0_PS = the 3 main power leads for all the computer components (motherboard, video card, drives, etc.)
except for power to the display and standby power (pins 11,12,13)

- Only energized when the PS_ON is tripped

SMB_ACDC_SCL_RC and SMB_ACDC_SDA_RC = Power for the system management bus controls and clock functions (pins 2,10)

- SDA stands for Serial Data. SDA lines are used to carry the actual data bits being communicated between the computer components/peripherals
- SCL stands for Serial Clock. The SCL line generates the clock signal that ensures all components/peripherals remain synchronized in their communication

Inverter +/- = Power to the LCD inverter board and ultimately the LCD backlight (pins 8,14,15,16)

- Only energized when the PS_ON is tripped
- The “Inverter –” pins are simply ground pins for the inverter board to connect back to system ground

5. It is easiest to use the existing wiring harness that connects the power supply to the inverter board and the main logic board in the iMac.

- The wires that would normally connect to the main logic board will be used to supply power to the LCD driver board and other internal components
- Carefully cut away the sleeve that bundles the wires from the power supply to the 14-pin logic board connector. This is necessary so you can easily determine which wires connect to the pins at the power supply connector and the inverter connector.
- Cut all the wires where they connect to the 14-pin main logic board connector since it will not be used (**NOTE: Do NOT cut the wires at the power supply connector [16 pins] or the inverter board connector [6 pins]!!**)
- Trace the wires to the 16-pin power supply connector and the 6-pin inverter connector and mark them for easy future reference using tape or another simple marking method
 - The wires from pins 11, 12, 13 (and a couple of the GND pins) will be your main power source for the LCD driver board and the fan controller
 - The wires from pins 6 and 7 are used for the PS_ON pushbutton described in paragraph 3 above
 - Find the two small wires that run between the logic board connector and the inverter board (i.e., two wires that bypass the power supply connector) – these are your BL_ON (or ENA) and PWM wires for the inverter!

Power pushbutton installation

1. Use an appropriately sized drill bit (12mm for the pushbutton I used) to drill a hole in a convenient place on the iMac case for the button location
 - I put my button on the bottom of the case to the left of the RAM access cover (see picture below). Ensure your drill bit is centered before drilling as the fit for the button in this location is a bit tight
 - If you intend to use the original iMac fans, make sure you drill this hole far enough to the right to allow room for the fan to be re-installed in the case
2. **I recommend having most of the internal components, especially the power supply and inverter, removed before you drill your hole to prevent metal shavings from getting into them as you drill**
3. Clear the hole of drill shavings or burs and insert the pushbutton
4. Connect the pushbutton wires to the wires for pin 6 and pin 7 of the power supply connector
5. Install the power supply and conduct a test by checking for 12Vdc at the wires from pins 11,12, and 13 when the pushbutton is latched. (**NOTE: Ensure you have the cut ends of all the loose power supply wires properly insulated and away from metal before you test the pushbutton functionality**)



Brightness control pushbuttons (Only required if you do not desire to use software methods to control display brightness – See “Brightness Control Options” a couple pages down)

1. Use an appropriately sized drill bit (12mm for the pushbuttons I used) to drill two holes in a convenient place on the iMac case for the button location – one to increase brightness and one to decrease
 - I put my buttons on the bottom of the case to the right of the RAM access cover (see the picture below). Ensure your drill bit is centered before drilling as the fit for the button in this location is a bit tight
2. I recommend having most/all of the internal components removed before you drill your hole to prevent metal shavings from getting into your power supply or inverter board as you drill
3. Clear the holes of drill shavings or burs and insert the pushbuttons to ensure proper fit. Do not connect them to the PWM board yet as there is more to solder to it later



Power to LCD driver board

1. Connect one of the PSU 12Vdc power wires (pin 11, 12, or 13) and a GND wire to one of the ‘power connectors’ (see “required parts” section above)
2. Plug it into the LCD driver board power port
3. Push the power button installed above and verify the LCD driver board gets power – you should see an LED on the skinny LCD controller board turn on (it will be green or red in color)

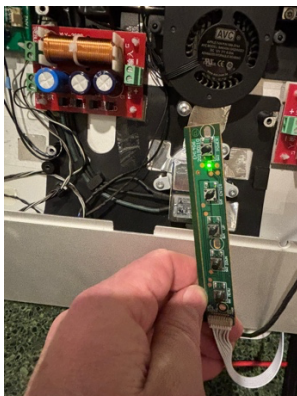

Connecting the LCD driver board to the iMac inverter board through the buck regulator, voltage step down board, and the PWM signal generator

1. Understanding the iMac Inverter board and its 6-pin connector – [This 6-pin MOLEX connector on the original wiring harness will be left fully intact and reused!](#)

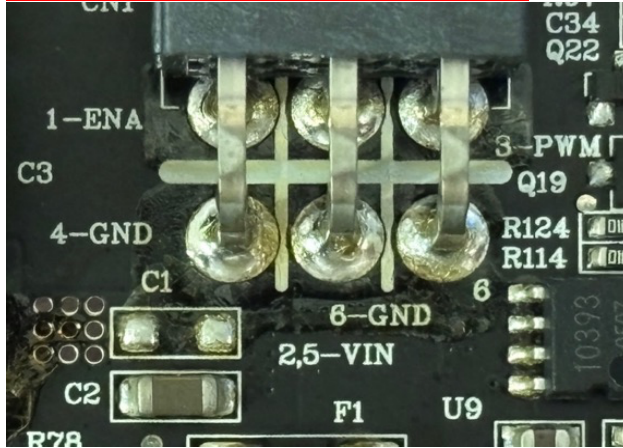

Pin 1 (ENA)	3.3 (4.94)	Pin 4 (GND)	0
Pin 2 (VIN)	12	Pin 5 (VIN)	12
Pin 3 (PWM)	3.3 (3.06)	Pin 6 (GND)	0
Pin 3 PWM Frequency	13.3kHz (36.03)		

***All values above are Vdc except for the PWM Frequency (kHz)

The values in the table above are from 3 sources:

- Pins 2, 4, 5, 6 are coming from the iMac Power supply (the “Inverter +” and “Inverter –” signals)
- The **red** values in parentheses for Pins 1 and 3 are the readings fed from the LCD driver board I purchased for my conversion.
 - Pin 1 (ENA) is coming from the BLO terminal on the LCD driver board
 - Pin 3 (PWM) is coming from the ADJ terminal on the LCD driver board

However, when connecting these to the iMac inverter, it always resulted in a black screen. Additional online research indicated that my inverter required different voltages and frequency values than those provided by the LCD driver board. There are lots of different sources of info for these with lots of different answers. Ultimately, I was able to find the schematics for the iMac Main Logic Board and confirmed the required values were 3.3Vdc and 13.3 kHz.

- The **black** values for Pins 1 and 3 in the table are the **required** voltage and frequency values specified in the schematics.
 - We will use these values to set the outputs of the dedicated voltage converters and the PWM board we will install inside the iMac case.

2. Connect one of the 12Vdc leads from the LCD driver board to the voltage step down converter board. To do this, we will be using the small 6-pin wiring harness that originally connected the constant current board to the LCD driver board. (Note: This is NOT the 6-pin MOLEX connector to the iMac inverter!!)

- Cut the 12Vdc wires and the GND wires in this 6-pin wiring harness. For my LCD board, these wires were red and black. Judge your cut location based off your planned layout for the boards in the iMac case so that these wires will be able to reach their destinations without any need for extensions.
- Feed one 12 Vdc wire and one GND wire to the appropriate input terminals on the voltage step down board

- Turn the power on and set the board to step down the **12Vdc input to a 3.3Vdc output** using the buttons on the board
- NOTE: Use a multimeter to measure the voltage output of the step down converters to ensure the LCD display is accurate. My board indicated about 0.07Vdc higher than actual voltage.
- NOTE: It may require many turns on the step down potentiometer on the board before the voltage begins to drop. **This is normal.**

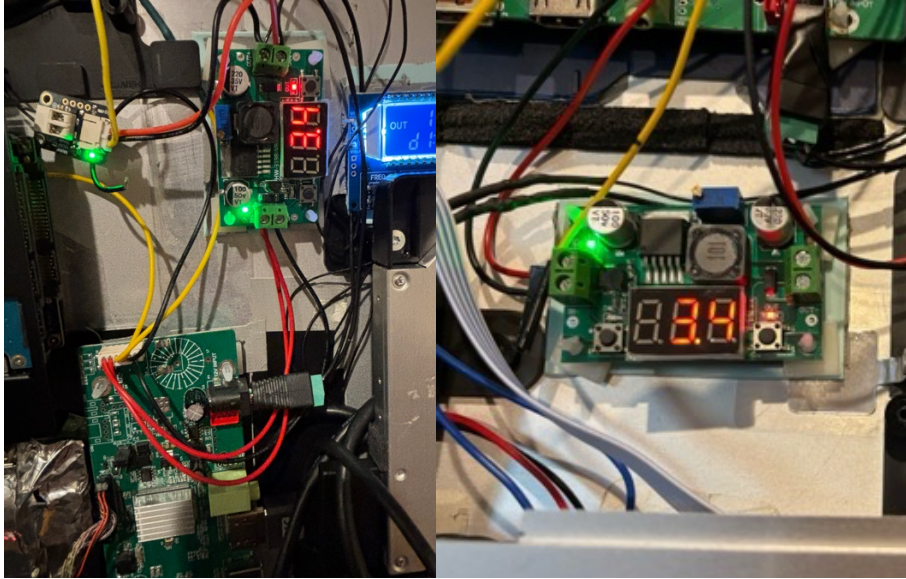

3. Connect the output of the voltage step down converter (12V to 3.3V) to the PWM signal generator and then connect the PWM signal generator to the iMac inverter

- Attach two additional wires to the **12V to 3.3V step down converter output** terminals
- Solder the other ends of these wires to the PWM board input terminals
- Solder the “PWM” wire connected to pin 3 on the iMac inverter MOLEX connector to the duty cycle output terminal of your choice on the PWM signal generator
- Turn on the power and set the PWM frequency to 13.3 kHz and the duty cycle of your desired port to 100% (Note: The duty cycle may require adjustment later to tailor the brightness level to your taste)
- *Use a multimeter to measure the voltage and frequency output of the PWM board to ensure the signal is correct.*
 - You should get **0.0 kHz** and **3.3Vdc with the PWM duty cycle set to 100%**.
 - Adjust the duty cycle downward to 95% and verify the frequency value (13.3 kHz) appears on your multimeter. (When the duty cycle is set to 100%, there is effectively no pulse generated. This is why the frequency at 100% reads 0.0 kHz)
 - The voltage value will also reduce in proportion to the selected duty cycle setting (e.g., 75% duty cycle will read $0.75 \times 3.3 = 2.48$ Vdc).
- I set my duty cycle to 75% as the starting value before I reinstalled my display.

4. Connecting the buck regulator to supply the ENA (or BL_ON) signal to the iMac inverter

- Cut the other 12Vdc lead (red wire) and GND lead (black wire) from the LCD driver board 6-pin wiring harness
- Also cut the “BLO” wire to the same length
- **Judge your cut location based off your planned layout for the boards in the iMac case so that these wires will be able to reach their destinations without any need for extensions.**
- Connect the 12 Vdc wire and GND wire to the appropriate input terminals on the buck regulator board
- Connect (solder) the “BLO” wire from the LCD driver board to the “ENA” pin on the buck regulator board. This controls the functionality of the buck regulator, turning it on/off as required by the LCD driver board.

- Connect the ENA (or BL_ON) wire coming from the iMac inverter harness to the output of the buck regulator board. **This sends a 3.3Vdc signal to the ENA (or BL_ON) terminal on the iMac inverter board which turns on the power to the inverter and provides the signals for sleep and wake functionality for the display. Note: no ground wire is required for this.**

Brightness control options

Because we have to replace the PWM signal from the LCD driver board with our own PWM controller, we lose the ability to control the brightness using the on-screen display of the LCD board. This leaves us with two options to restore brightness control capability.

Option 1: Use software such as Monitor Control (or Monitor Control Lite - Free in the App Store) or Better Display to control the brightness.

- Software methods adjust the **video** signal from the GPU instead of changing the actual PWM duty cycle of the backlight LEDs like the onscreen display menu of the LCD driver board does
- As a result, there is some color shift that occurs as the software brightens or dims the display
- This color shift is often undesirable, especially if working with color sensitive applications/needs
- However, it is easy. Simply download and install the software.

Option 2: Control the PWM duty cycle directly by installing two additional push buttons in the iMac case (momentary style push buttons instead of latching pushbuttons) and connecting them to the duty cycle button connections on the PWM board.

- This will allow us to easily change the brightness without the need for additional software
- This method adjusts the amount of time the backlight LEDs are energized and does not alter the video signal... thus, no color shift occurs
- This method requires soldering. Here are the steps to follow:
 1. Install the momentary latching pushbuttons as describe several pages above
 2. Solder the wires from the pushbuttons to the PWM board's duty cycle buttons - two wires each to the increase and decrease duty cycle buttons
 3. Ensure you don't mix up the wiring – 2 wires from one pushbutton to one duty cycle button (4 wires total)
 4. Depending on the length of your pushbutton wires, you may need to add an additional length of wire to ensure everything reaches inside the iMac

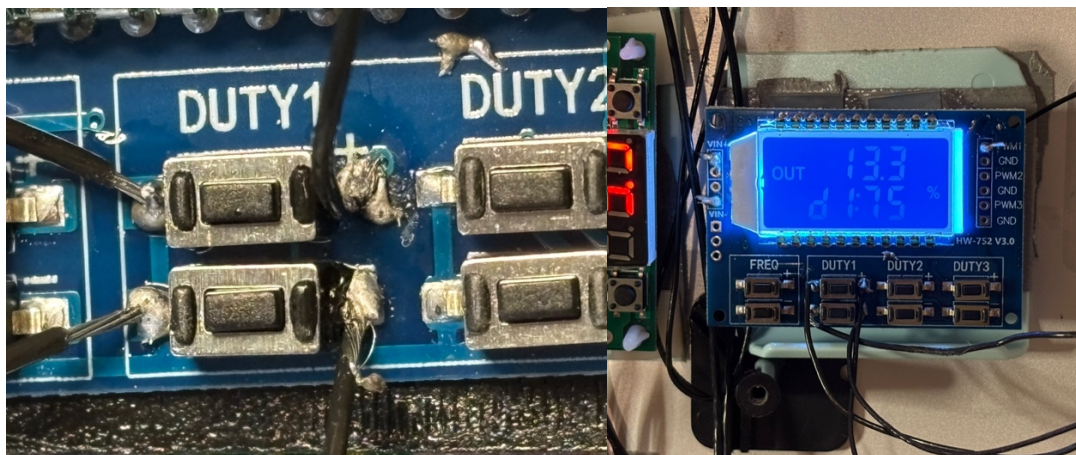

Test the display before moving on with any of the remaining internal components you desire to keep

Everything required to support display functionality is complete – best to test it out now before moving on with any other internal components

- USB Red SD Reader light brown
- USB White SD Reader purple
- USB Green SD Reader white

5. Connect the iSight camera. Much like the SD card reader, the iMac's SD card reader can be attached to a USB hub by converting its small iMac logic board connector to USB A or C. Here is the USB A wiring conversion:

- USB Black Camera black or dark gray
- USB Red Camera brown
- USB White Camera light gray
- USB Green Camera purple

NOTE: I did not restore the iSight camera in my conversion due to it being very out of date/poor quality by today's standards and the ease of using my iPhone and the Continuity Camera app included in MacOS Sequoia. [There are some in the MacRumors Forums that have replaced their iSight camera with newer/better components.](#) These might also be able to be used, but I did not explore that option.

Audio Setup

1. The speakers in my 2011 iMac are rated for 17 watts. However, the amplifier on my LCD board is only 3W per channel. I found it was satisfactory to provide the audio uses I have a need for. I attempted to boost the power to closer to 17W by installing an additional amplifier to the LCD driver board audio output, but I was not successful in eliminating the hum and interference that is often a problem when wiring amplifiers in series.

2. On my LCD board, the only audio output was from a 4-pin connector that is placed next to the 3W amplifier (labeled as NS4263). The other audio jack is an input feed for a separate audio source (i.e., audio not coming from the HDMI or DisplayPort connection).

3. Crossovers are required to feed the proper frequencies to the iMac tweeter and woofer.

4. The iMac speakers wires as follows: Brown/Gray wire pair is Treble +/- and the Black/Gray wire pair is Bass +/-

5. Connections:

- Connect the audio output from the LCD driver board to the crossover board inputs
- Connect the iMac speaker wires to the crossover board outputs – be sure you connect the treble wires to the treble outputs and the woofer wires to the bass outputs

Cooling Fan and Fan PWM Board Installation

I operated the display for a week (approximately 8 hours a day) without any extra cooling and it seemed to do well. However, the back of the iMac case does get warm behind the PSU and the inverter. Given that these components are both over 13 years old and the amount of effort I put into this conversion, I decided to be extra conservative and install two small fans and fan PWM controller below the PSU to provide some cooling.

1. To make the connection to the fan PWM board easiest, I recommend using a 12Vdc fan and controller. This will eliminate the need for any additional voltage step-down.

2. I recommend cutting away the plastic iMac air dam that fits at the bottom of the inverter to improve the airflow coming from the bottom of the iMac case up and behind the inverter board and then out the top of the case.

3. Connect one of the 12Vdc and GND wires from the iMac power supply to the fan PWM board.

4. Place one temperature probe above the inverter and power supply. If using two fans, place one probe above the inverter and one above the power supply.

5. Connect the fan wires to the fan PWM controller and mount the fans in your desired locations. (NOTE: I used the same plastic standoff mounts that I used for the circuit boards to mount the fans as well).

6. Set the fans to operate to maintain your desired internal temperature.

7. If you desire to use the iMac fans, you will need to map the four wires coming from the fans to the appropriate wire for connecting to the fan PWM board(s).

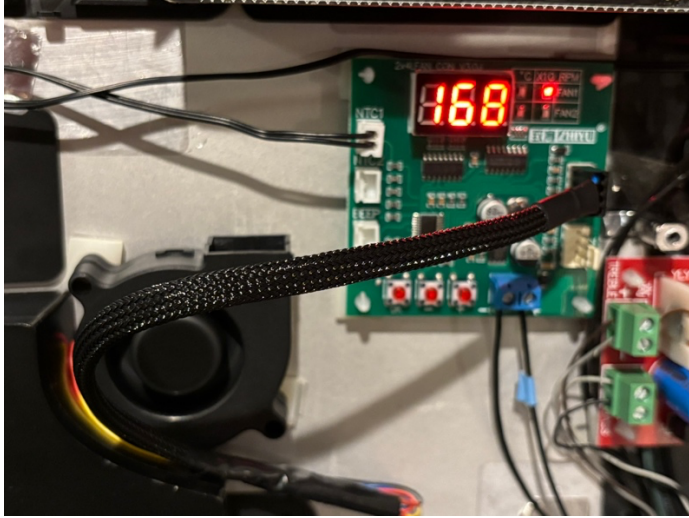

Internal picture of my iMac after the conversion

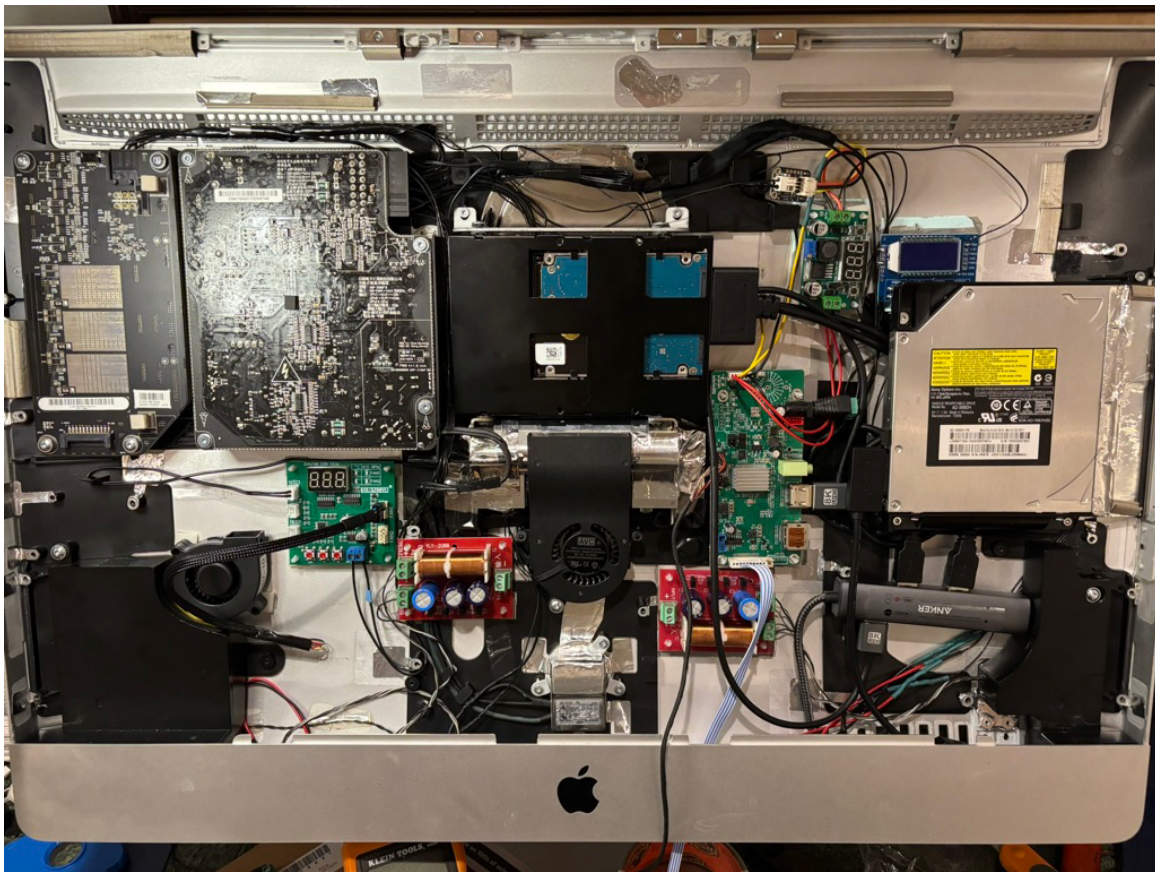

iMac motherboard power supply connection – 14 pin MOLEX connector (providing for reference only)

Note: The iMac main logic board schematics show Pin 12 is BL_EN and Pin 13 as PS_ON. This is the reverse of what is shown above from the service manual

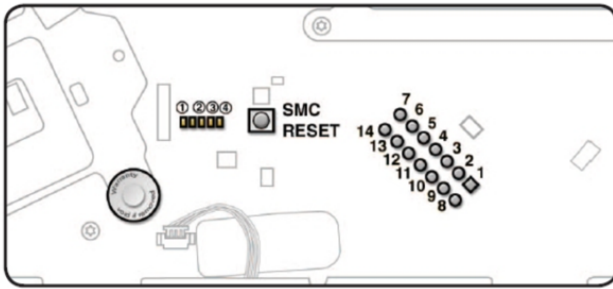

Test Point	Function
Pin 1	Ground
Pin 3	5V power for Hard Drive(s). Note: If present, the 12V power will come directly from the Power Supply to the Hard Drive thru the power harness cable.
Pin 4	Standby 12V power (permanent power coming from power supply, present as long as AC cable is connected, even if computer is off); corresponds to LED #1
Pin 6	Backlight Control pulse width modulated signal (from logic board to LED backlight board, to adjust the backlight level setting according to user setup)
Pin 11	12V Run-Mode power to logic board (coming from power supply, present as long as system is on or asleep); corresponds to LED #2
Pin12	Power On Request signal (from logic board to power supply when power button is pressed)
Pin 13	Backlight Enable (signal from logic board to Backlight Controller board, to enable backlight)

Graphics depicting the connections between each of the components

Component Wiring Diagram

